



**Coldefy &
Associés
Architectes
Urbanistes**

Une serre tropicale

TROPICALIA

CARNET DE PLANS - NOTICE D'ACCESSIBILITÉ
Rang-du-Fliers/Verthon | MAI 2019

**Coldefy &
Associés
Architectes
Urbanistes**

13 rue Jean Prouvé
59000 Lille France
T +33 3 20 40 26 80
F +33 3 20 42 91 01
SAS CAPITAL 135 000 euros
RCS LILLE B 391 735 156



OPALE TROPICAL CONCEPT

CAT-Aéroport International 62520 Le Touquet

SAS au capital de 150 000 euros - RCS Boulogne 818 403 180
TVA FR 66 818 403 180 - SIRET 818 403 180 00016





9.43 SURFACE DU TERRAIN EN HA
20 000 SURFACE DU DOME EN M²
150 x 200 LARGEUR PAR LONGUEUR EN M
32 HAUTEUR DU DOME EN M
28 TEMPERATURE DANS LA SERRE EN °C
500 000 NOMBRE DE VISITEURS PAR AN
100 AUTONOMIE EN %

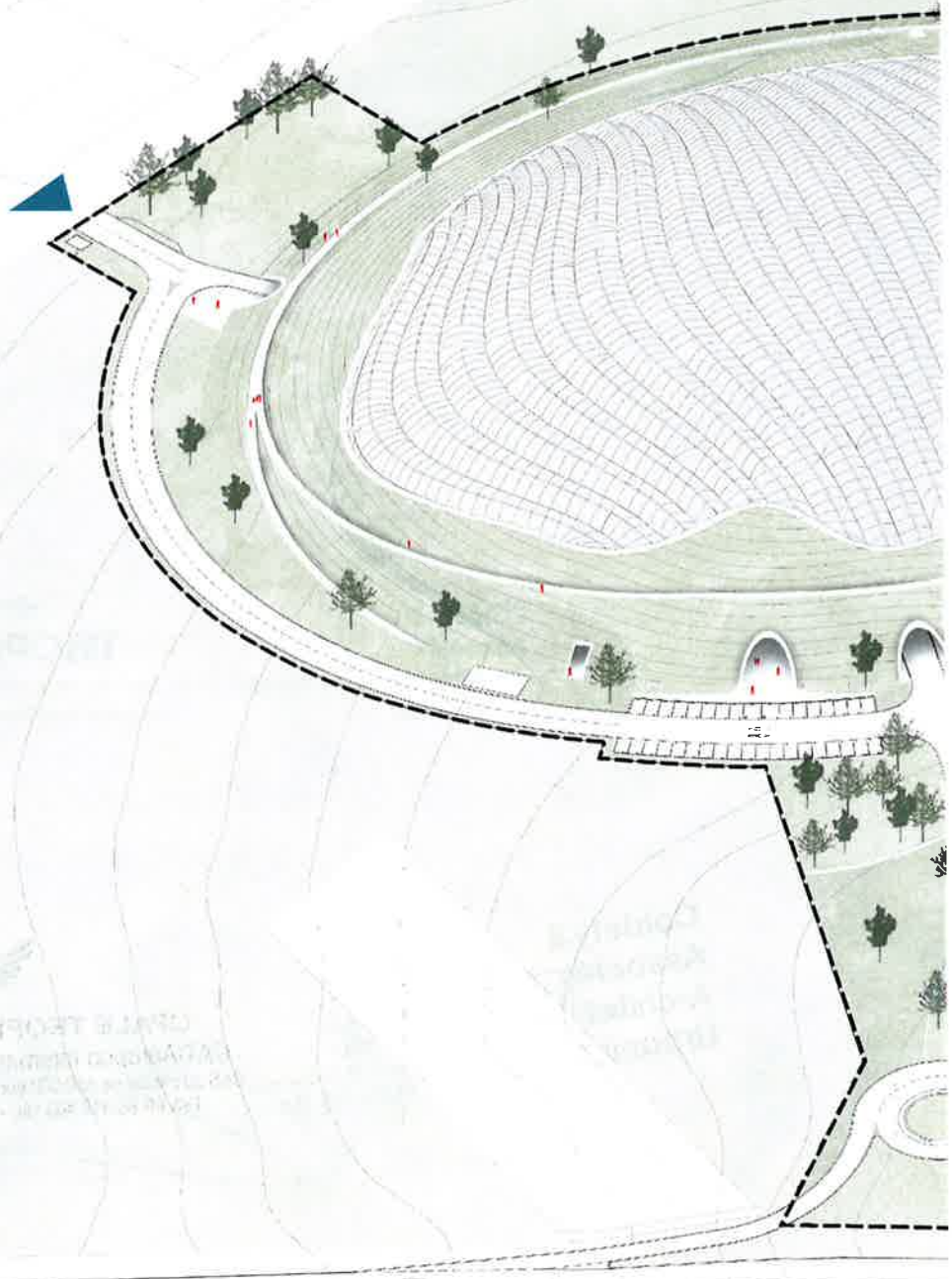



▲ ACCES GENERAL VEHICULES ET BUS

■■■■ CONNEXION PIETONNE AVEC TRAME VERTE ET GARE

⋯ CIRCUITS BUS ET VEHICULES

〰 DEPOSE MINUTE

● VESTIAIRES/SANITAIRES

▲ ENTREE PRINCIPALE PUBLIC SERRE

▲ ACCES SECONDAIRE

▲ ENTREE ENTRETIEN

▲ ENTREE PERSONNEL

▲ ENTREE LIVRAISON

■■■■ VOIE POMPIERS

▲ SORTIE DE SECOURS

PARKING PUBLIC VEHICULES

12300 m²
568 places
dont 20 PMR

PARKING BUS

2200 m²
20 places

PARKING PERSONNEL

740 m²
36 places
dont 2 PMR

ACCES PERSONEL ENTRETIEN ET LIVRAISON

ENTREE ENTRETIEN

PARKING PERSONNEL

ENTREE PERSONNEL

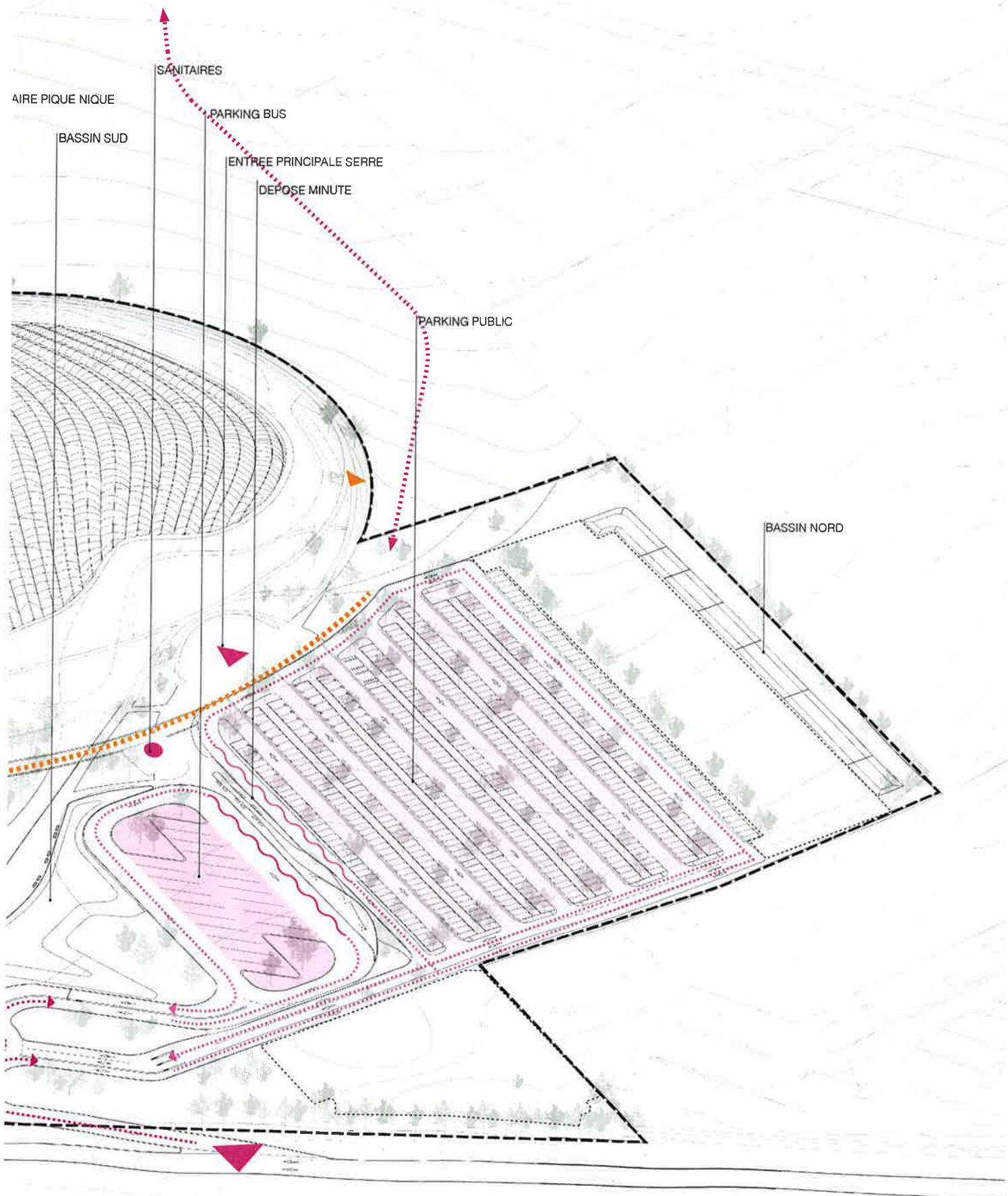

ENTREE LIVRAISON



PLAN MASSE

ACCÈS PUBLIC / PRIVÉ

PUBLIC

-  ACCÈS VÉHICULE
-  CIRCULATION PIÉTONNE
-  PLACES PARKING PMR

PERSONNEL - LIVRAISON

-  ACCÈS VÉHICULE
-  CIRCULATION PIÉTONNE
-  PLACES PARKING PMR





PARCELLE ZA 6

PARCELLE ZA 1
"LE CHAMP
GRETZ"

NIVEAU BAS 31 NGF

PLAN DE REPÉRAGE REGLEMENTATION ERP / CODE DU TRAVAIL

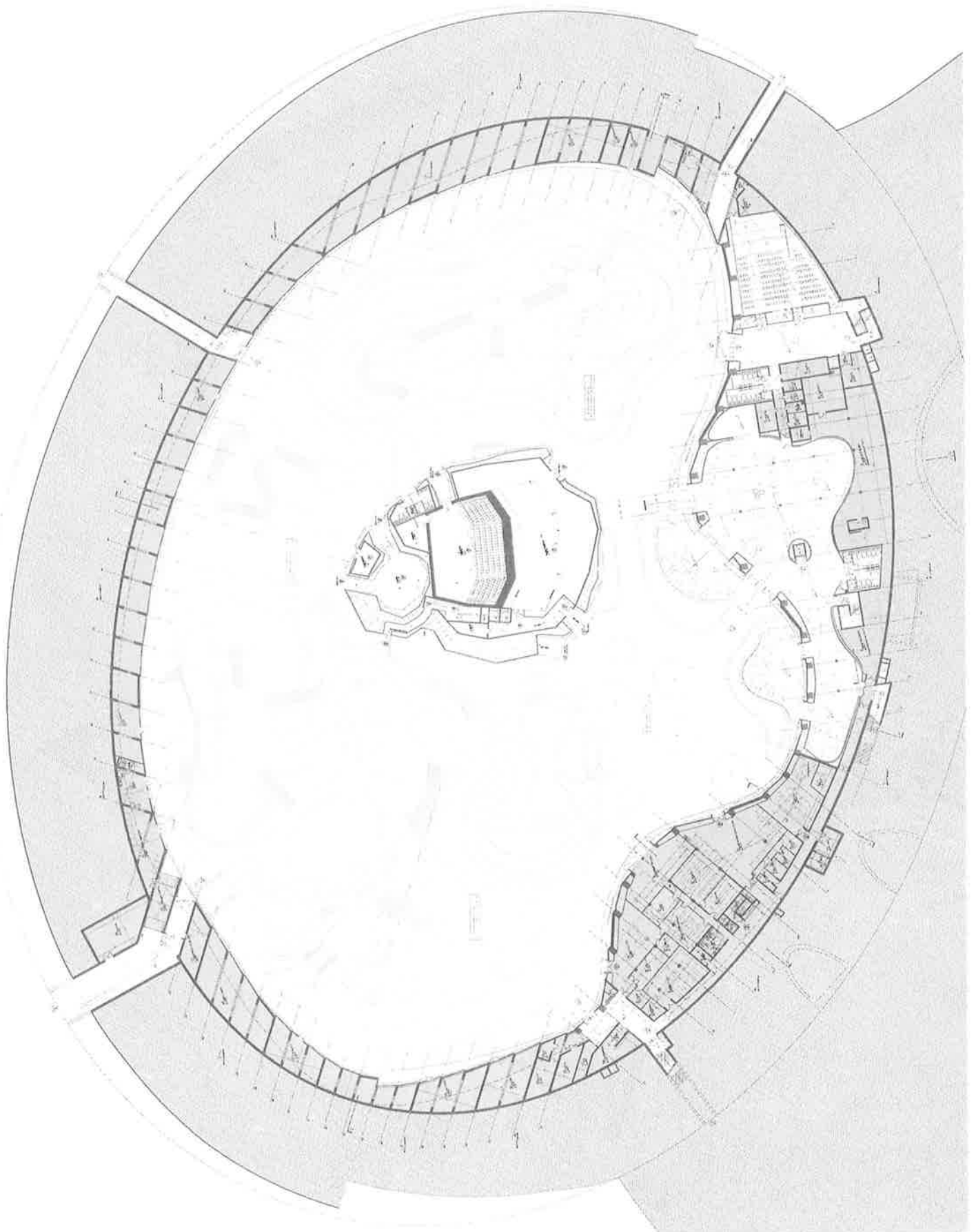

NIVEAU HAUT 36 NGF

- REGLEMENTATION CODE DU TRAVAIL
- REGLEMENTATION ERP

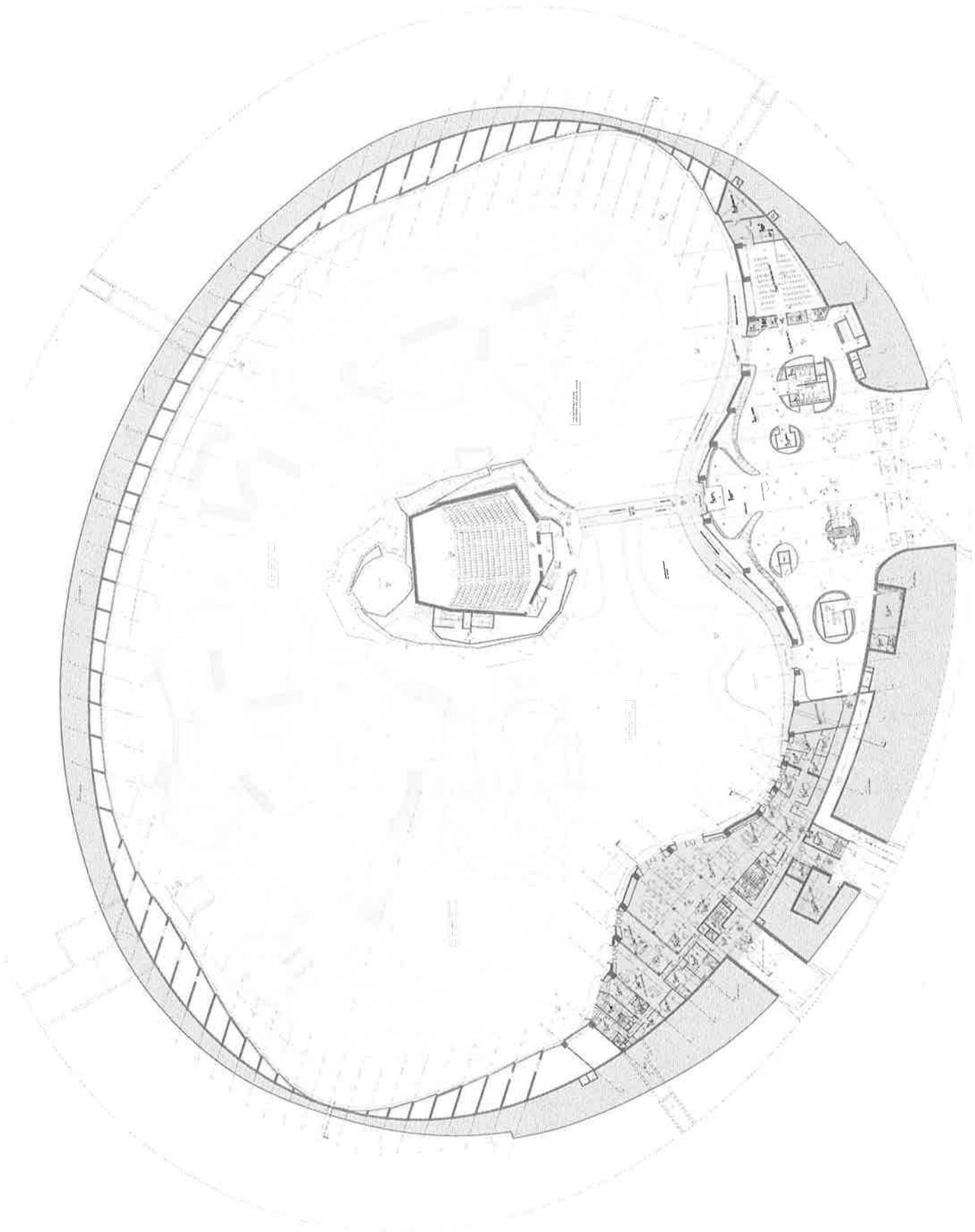

NIVEAU BAS 31 NGF



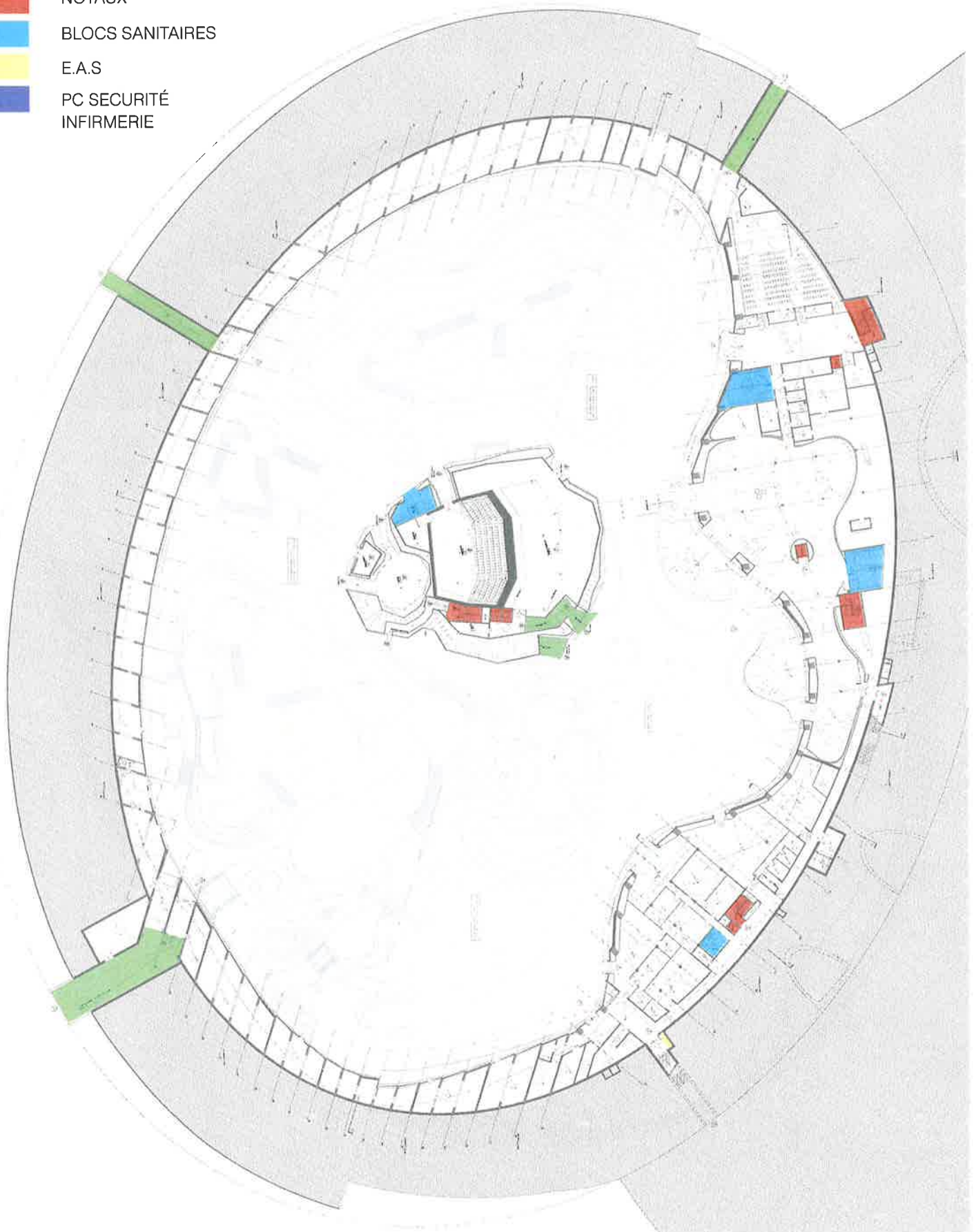

PLAN DE REPÉRAGE ACCESSIBILITÉ PMR

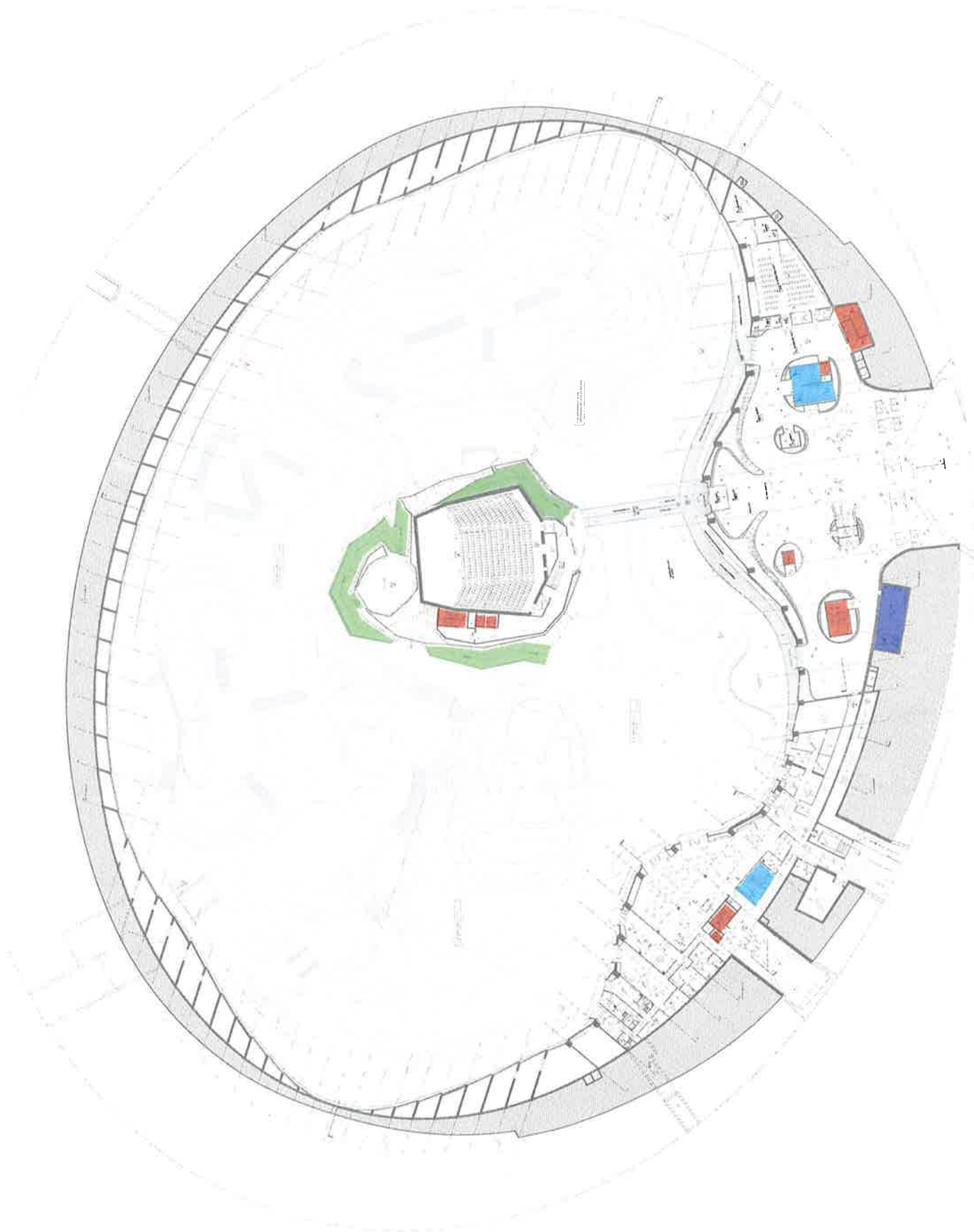
-  RAMPES PMR
-  NOYAUX
-  BLOCS SANITAIRES
-  E.A.S
-  PC SECURITÉ
INFIRMERIE





MONTAGNE

-  RAMPES PMR
-  NOYAUX
-  BLOCS SANITAIRES
-  E.A.S
-  PLACES PMR AUDI.

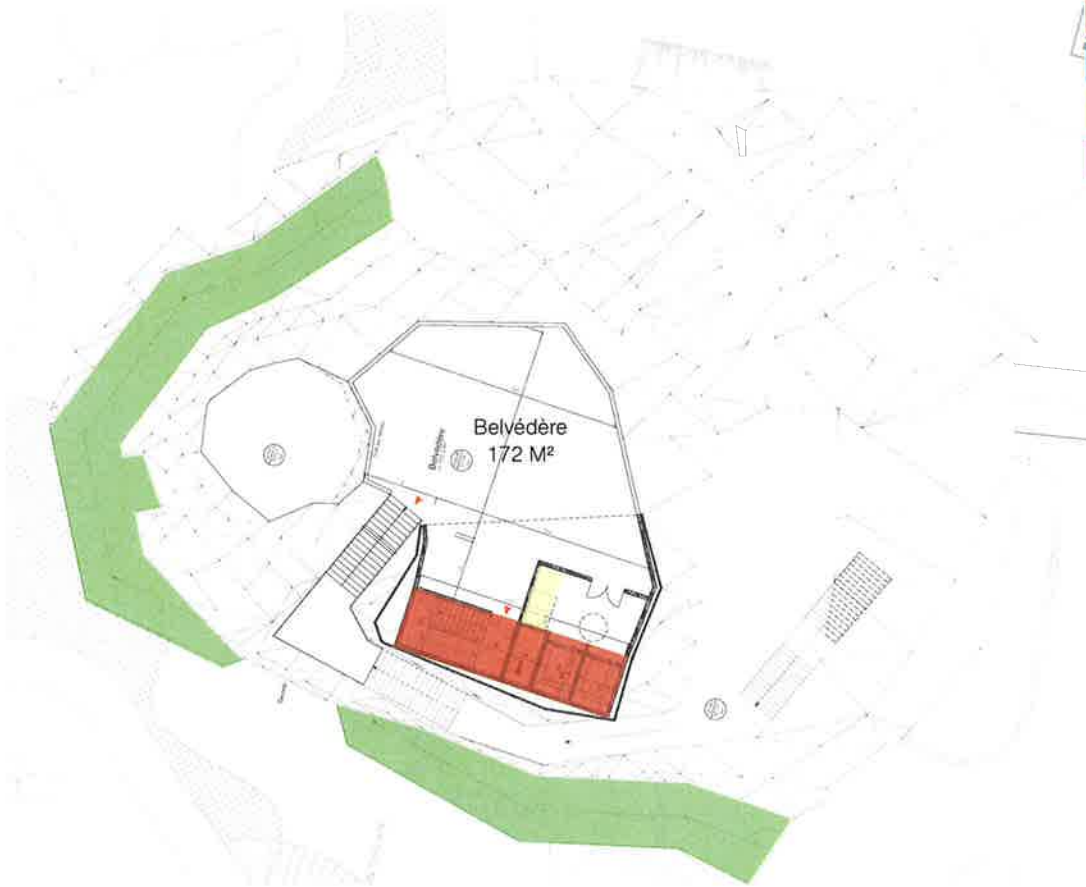

PLAN NIV. 50.00 NGF - BELVÉDÈRE

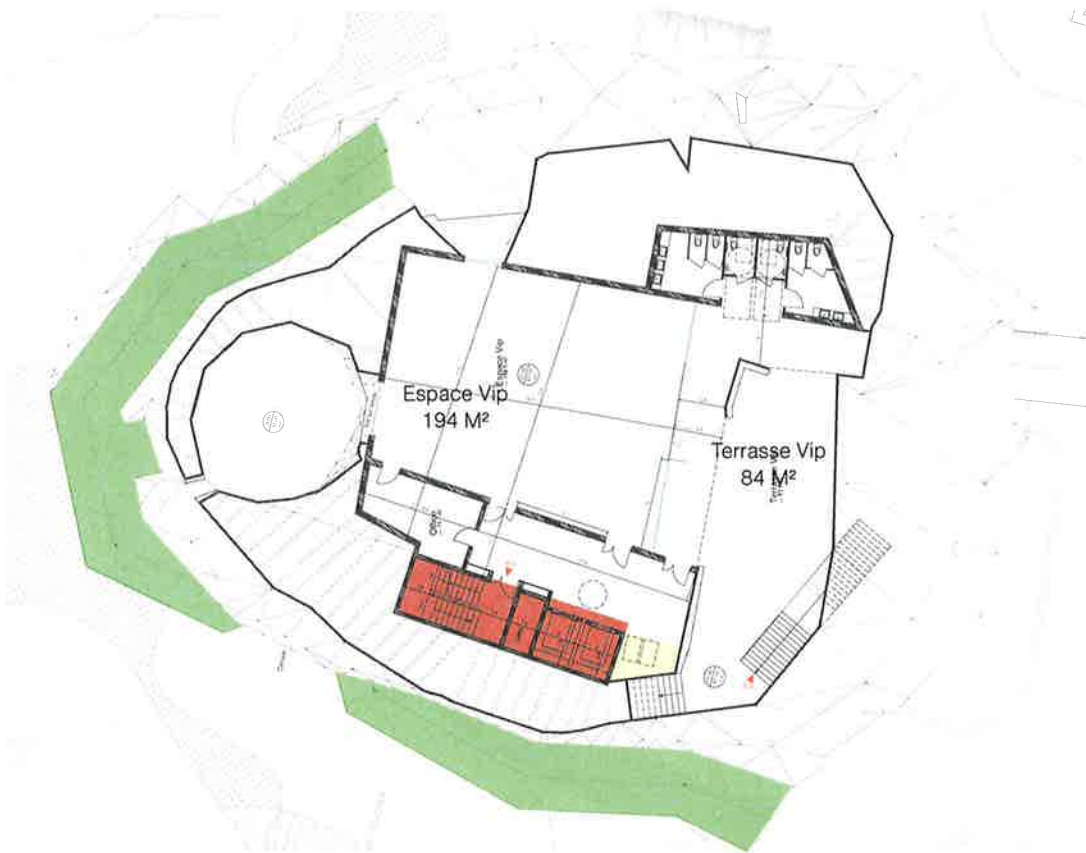

PLAN NIV. 41.00 NGF - ESPACE VIP

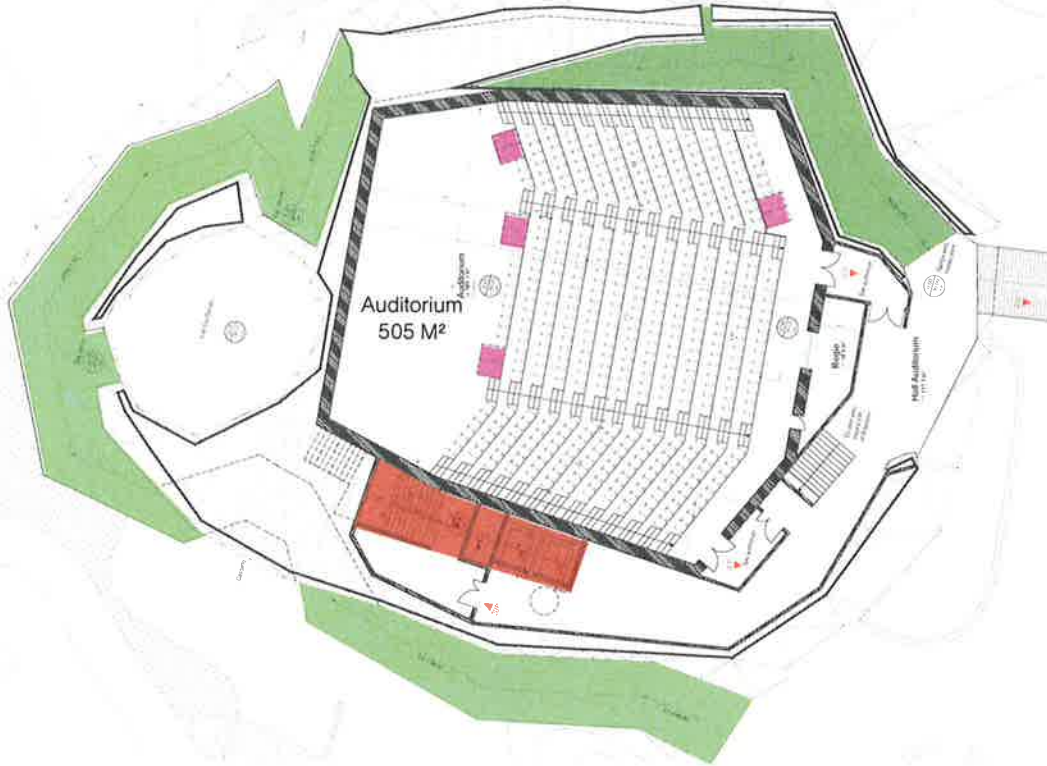

PLAN NIV. 36.00 NGF - AUDITORIUM



PLAN NIV. 31.00 NGF-MUSÉE PAPILLONS

EXTRAIT DE PLAN

BANQUE D'ACCUEIL ET CAISSE BOUTIQUE

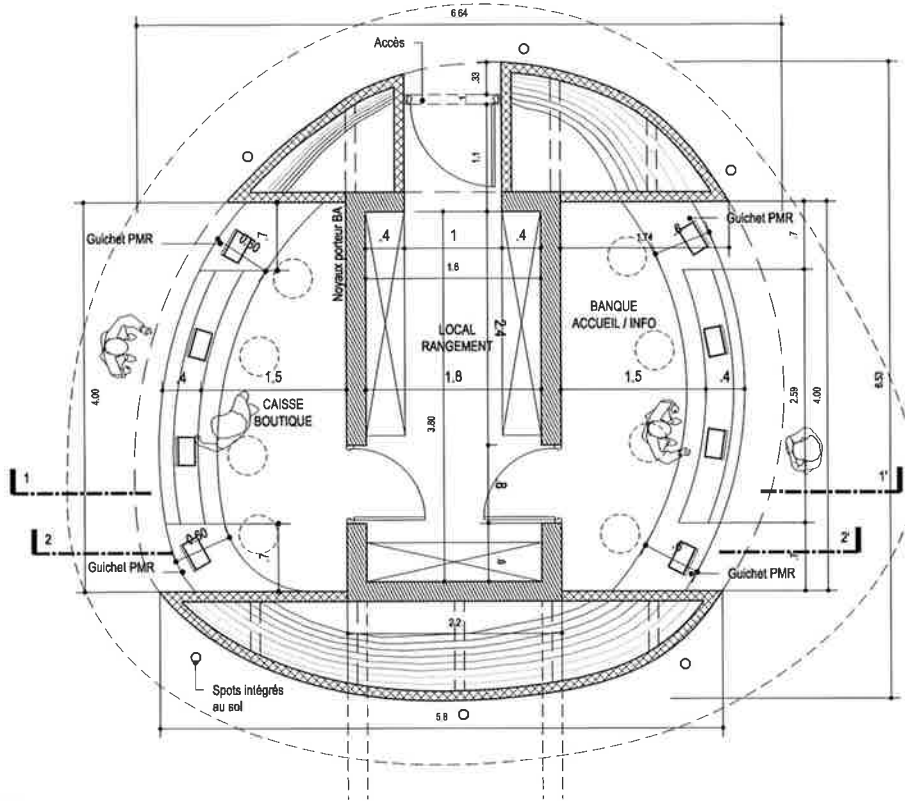

PLAN DETAIL BANQUE D'ACCUEIL

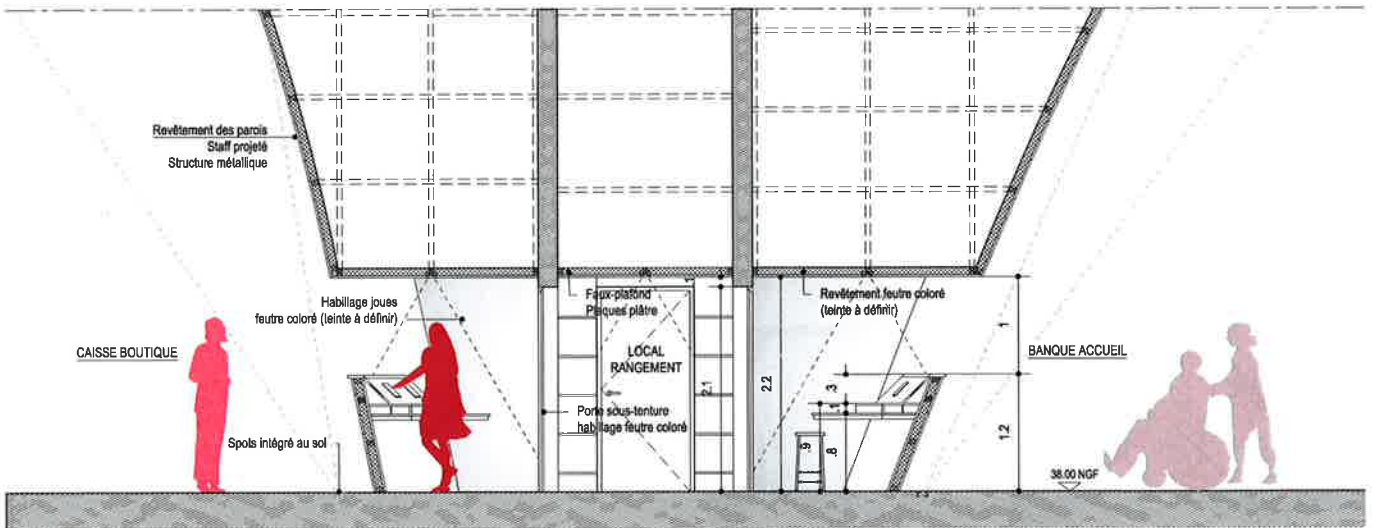

COUPE 1-1'

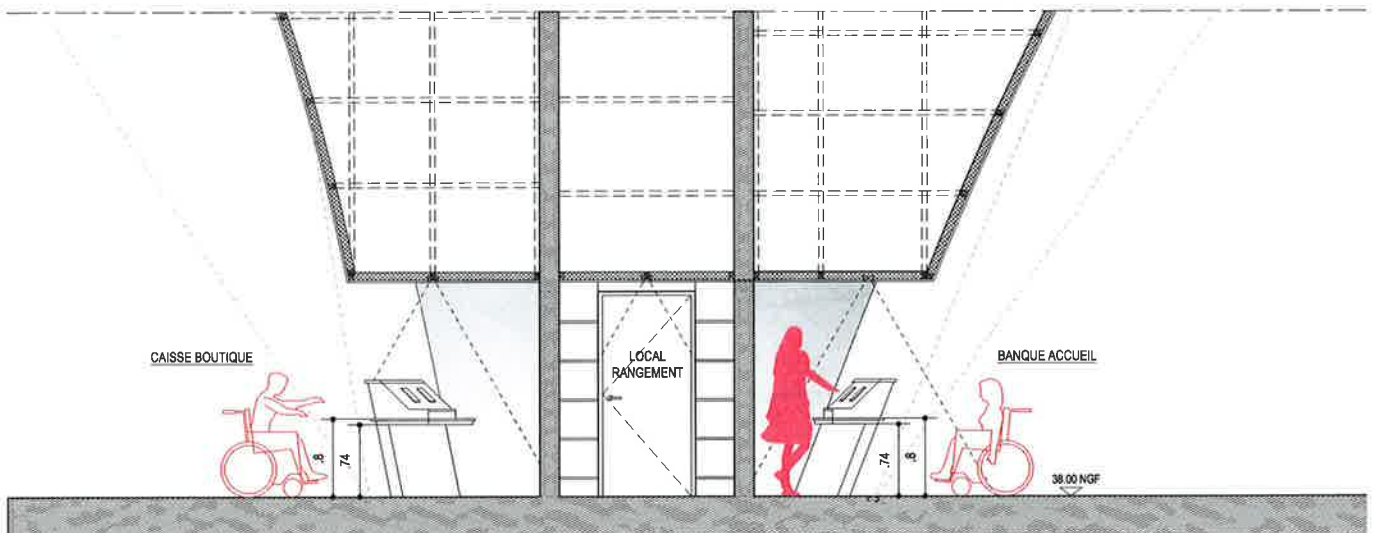

COUPE 2-2'

EXTRAIT DE PLAN
BLOC SANITAIRE HALL D'ENTRÉE

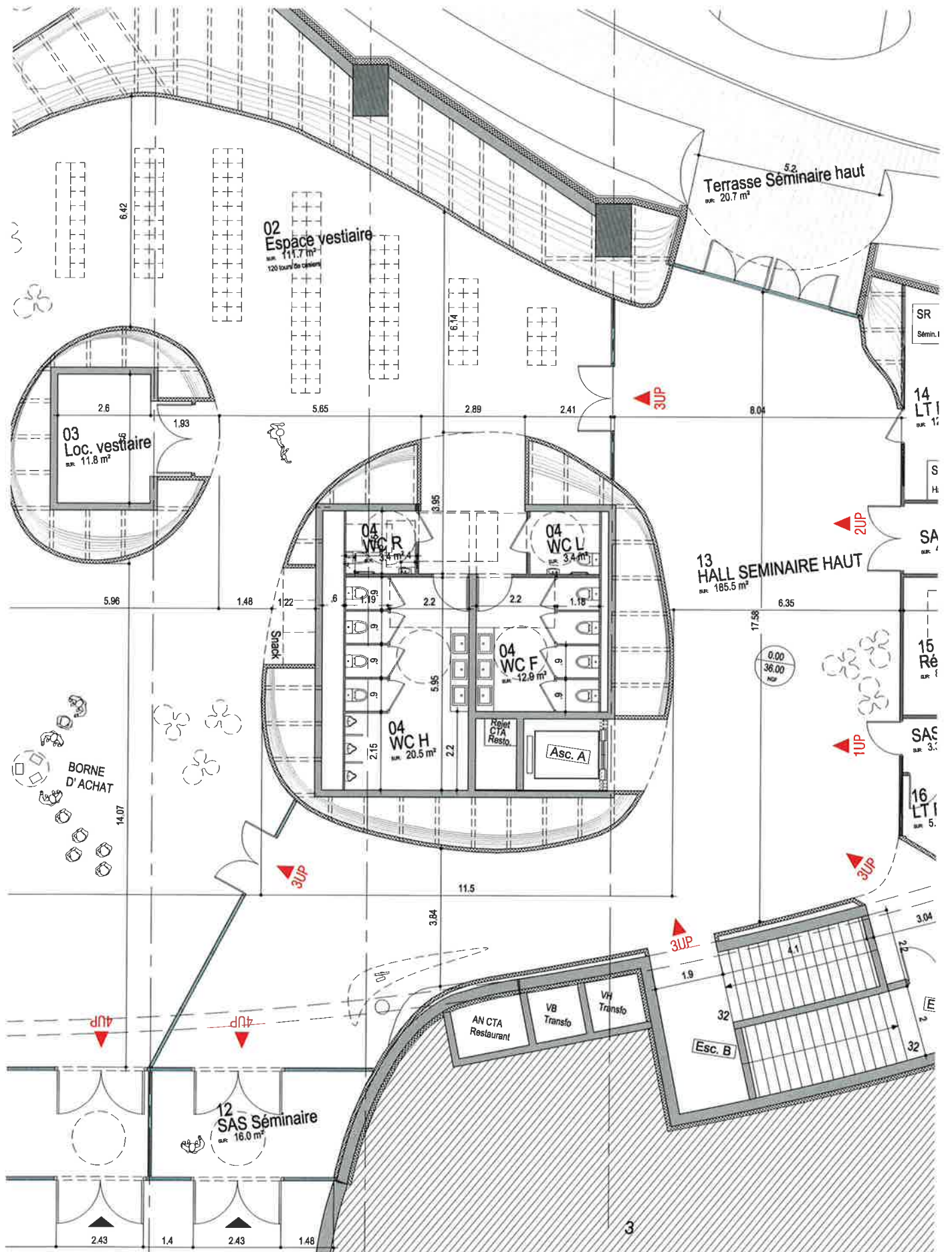

EXTRAIT DE PLAN
BLOC SANITAIRE EXTÉRIEUR

